

Technical Data Sheet

MSJS

Matrix-Sealing Jaw Standard

Digital Heating System designed for sealing applications

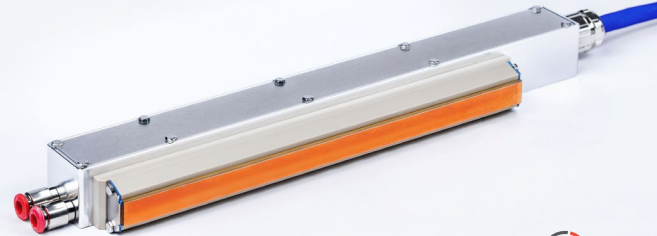

cera2seal

Parameters

Sealing Surface/Area ¹⁾

Sealing width	2 to 20 mm in steps of 1 mm
Sealing length	120/160/200/240/280/320 mm
Profile	Flat
Materials used	Sealing surface: copper-based alloy housing: anodized aluminium, PEEK cable gland: brass, nickel-plated

Connection Cable ¹⁾

Cable type	Hybrid cable (heater, control and communication cable integrated), cable sheathing: PUR
Connector type	Harting® Han 6B ¹⁾ , made of die-cast aluminum, powder-coated
Length	1.5 m (cable extension available separately)
Diameter	12...14 mm
Minimum bending radius	100 mm
Pin assignment	See appendix

Environmental Conditions

Ambient temperature	5 °C to 40 °C (41 °F to 104 °F)
Maximum relative air humidity	80 % at temperatures up to 31 °C (88 °F), decreasing linearly up to 50 % relative humidity at 40 °C (104 °F)

Internal Air Cooling ³⁾

Purity class ISO 8573-1:2010	No restrictions
Pressure	1 bar
Flow rate	15 l/min

Standards

Underwriters laboratories (UL)	-
Ingress protection (IP)	Design according to IP50

Nominal Electrical Power

450...900 W (sealing length 120...320 mm) ²⁾

Nominal Voltage

36 V DC

Performance / Energy Density

15...50 W/cm² ²⁾

Sealing Temperature

Up to 250 °C (482 °F)

Temperature Accuracy

± 1 K

Nominal Heat Up Rate

10 K/s

Maximum Surface Pressure

1 MPa (on the sealing surface) ²⁾

¹⁾ Customizing on request

²⁾ Depending on different models – see appendix

³⁾ From 150 °C continuous operating temperature the cooling of the electronic housing is required (depending on environmental conditions).

watttron Inc.

150 N Michigan Ave 35th Floor – Chicago, IL 60601

+1 (312) 665-0984

sales@watttron.com

www.watttron.com

Machine Type Usecases

HFFS

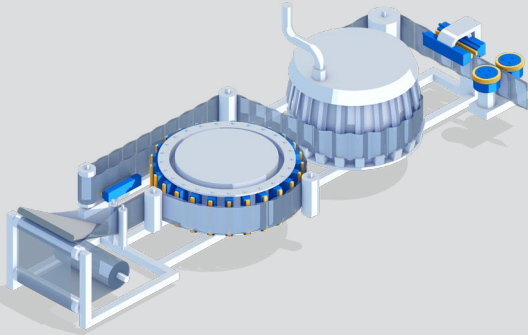

HFFS linear

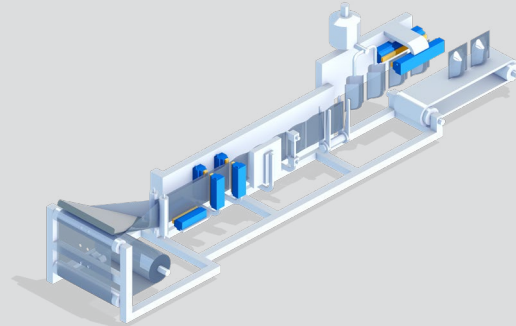

VFFS

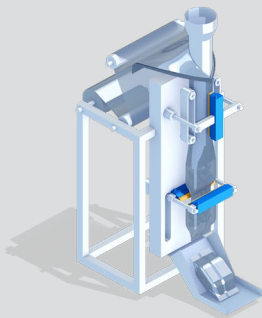

Machine PLC Integration Models

Partial Integration

Sealing-system, control and powersupply completely independent of the packaging machine

Suitable for lab and pilot purpose
Separate HMI required (can be provided)

No communication with the machine

Basic Integration

Digital In/Out
"Only" read signal
On/Off-status

Suitable for pilot purpose
Separate HMI required (can be provided)

Digital machine communication

Full Integration

Full access to watttron functionality
Bi-directional communication

Suitable for industrial application
Fully integrated into the machine control/HMI
(separate HMI also possible)

Ethernet/fieldbus machine communication

Benefits



Precise Temperature Control

Precise temperature control at the surface and profiling (pixel by pixel) for different and complex sealing processes. Full dynamic adjustment of the heating power to the local requirements. This ensures consistent and repeatable sealing results, even with difficult to process materials.

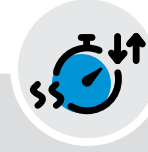

Fast Heat Ramp and Cool Down

Fast temperature ramp-up and fast cool-down, saving energy and production time. Increased operator safety due to ability to turn off while production stops and fastrestart.



Save Material and Energy

Low thermal mass because only the sealing surface is heated. Fast ramp-up times ensure minimized energy consumption. Energy saving due to focussed heat supply and less heat transfer to the environment.



Retrofit Existing Machinery

Fits into most common HFFS machines as vertical seal or VFFS as length seal. No need for changes of the machine.

Graphical User Interface

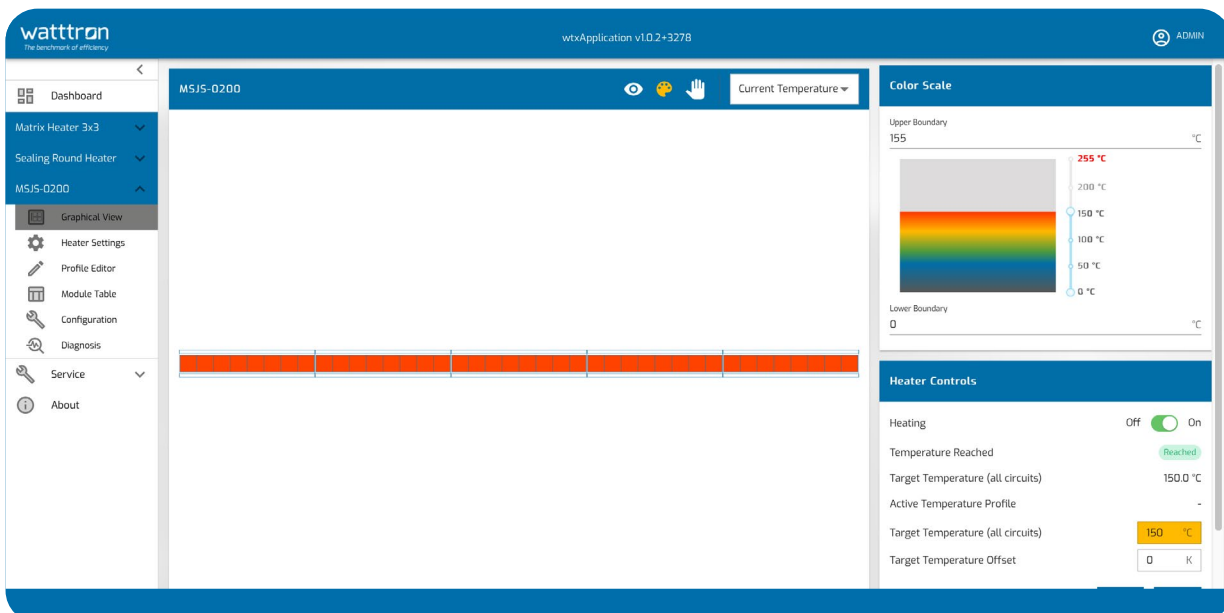

*Further details see documentation watttrixServer

Drawing

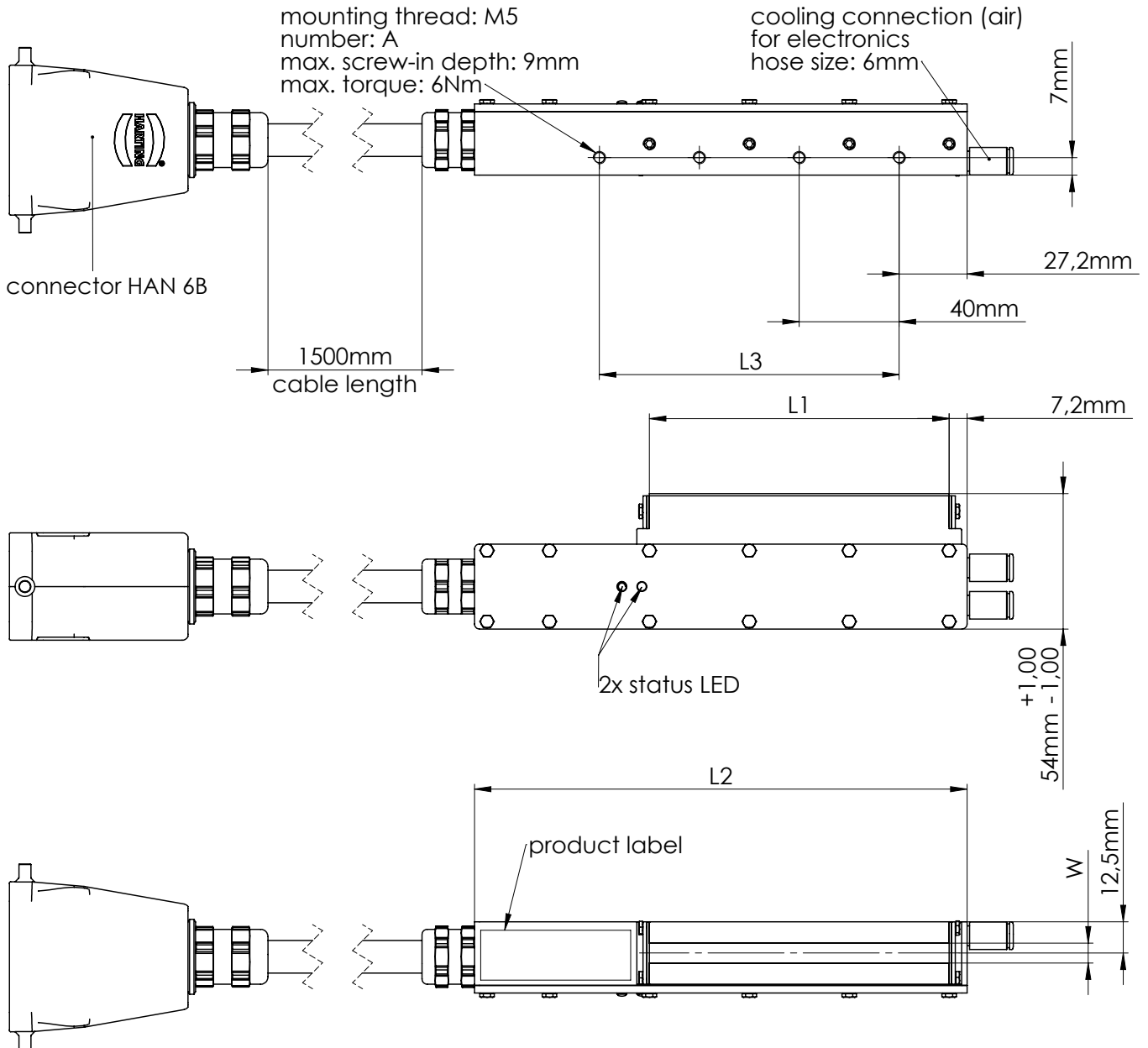

L1 (length of sealing-area)	L2 (total length of housing)	W (width of sealing-area)	L3 (mounting length)	Nominal electrical power (36 V DC)
120 mm	197,2 mm	2...20 mm	120 mm (A=3)	450 W
160 mm	237,2 mm	in steps of 1 mm	160 mm (A=4)	540 W
200 mm	277,2 mm		200 mm (A=5)	630 W
240 mm	317,2 mm		240 mm (A=6)	720 W
280 mm	357,2 mm		280 mm (A=7)	810 W
320 mm	397,2 mm		320 mm (A=8)	900 W

Options Cable Outlet and Cooling Connections

sideways angled

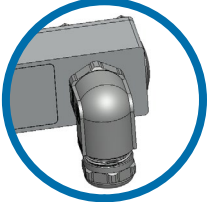

front side angled

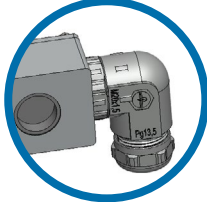

sideways straight

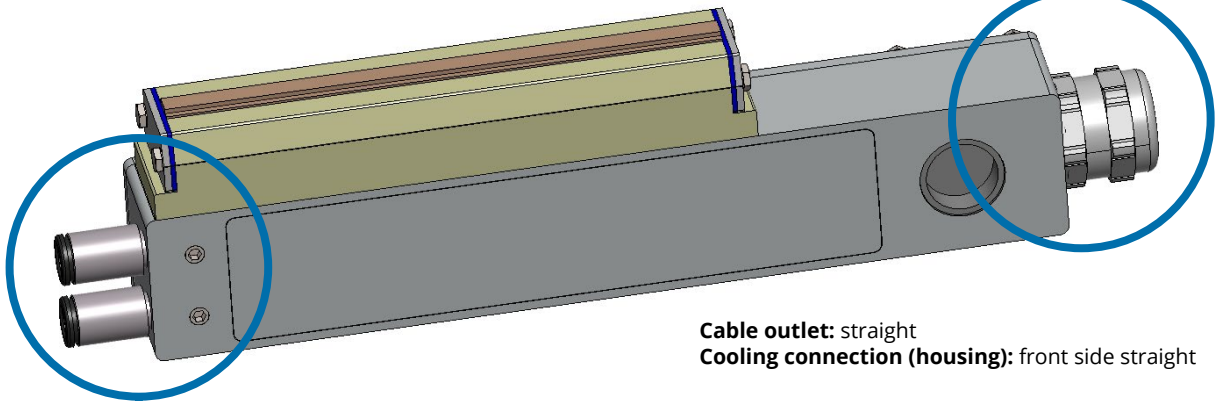
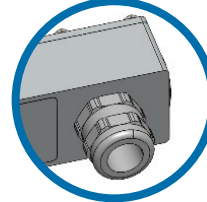

Cable outlet: straight
Cooling connection (housing): front side straight

sideways straight

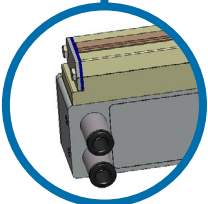

Sealing Width

2 to 20 mm in steps of 1 mm

Basic module widths: 8 mm, 12 mm, 16 mm, 20 mm. Intermediate widths are offered on the basis of these basic modules in the form of steps.



Sealing Profiles (on request)



flat

curved

serrated

stepped

Pin Assignment

HARTING Han® 6 B industrial plug (m)

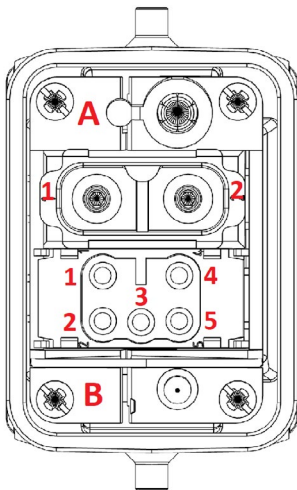

Pin	Assignment
A1	+ 36V DC heating voltage
A2	GND heating and control voltage (24/36V)
B1	+24V DC control voltage
B2	POS (optinal usable)
B3	GND data
B4	Bus data (RS485) D+
B5	Bus data (RS485) D-
PE	PE